

Copyright of this drawing is retained by Masefields Marchant Brabbs Limited, not to be reproduced or copied without written consent.

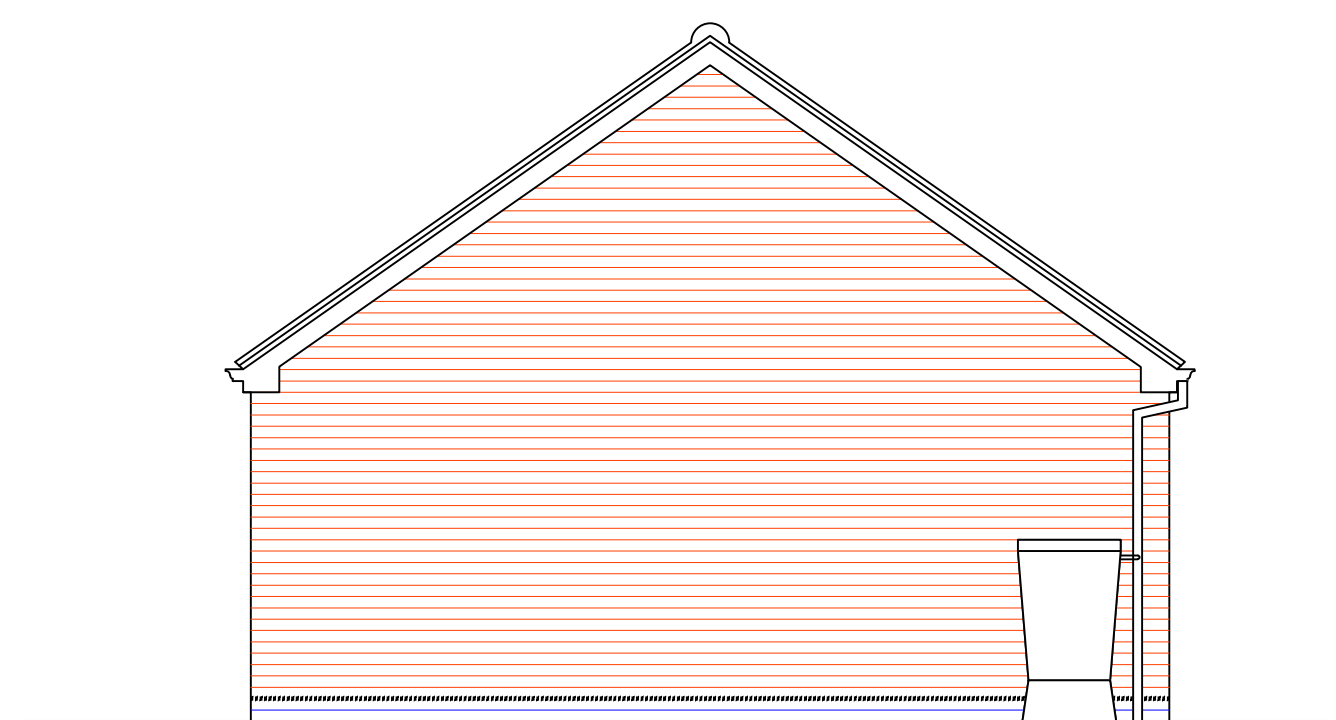

SIDES 1 & 2

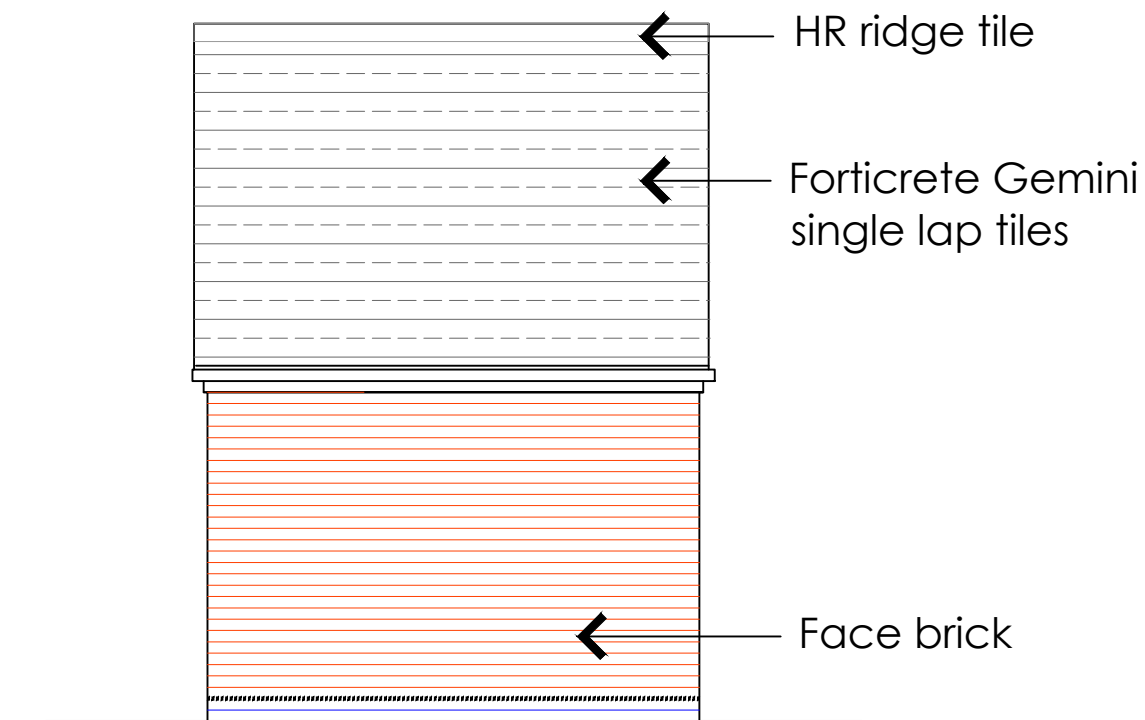

REAR

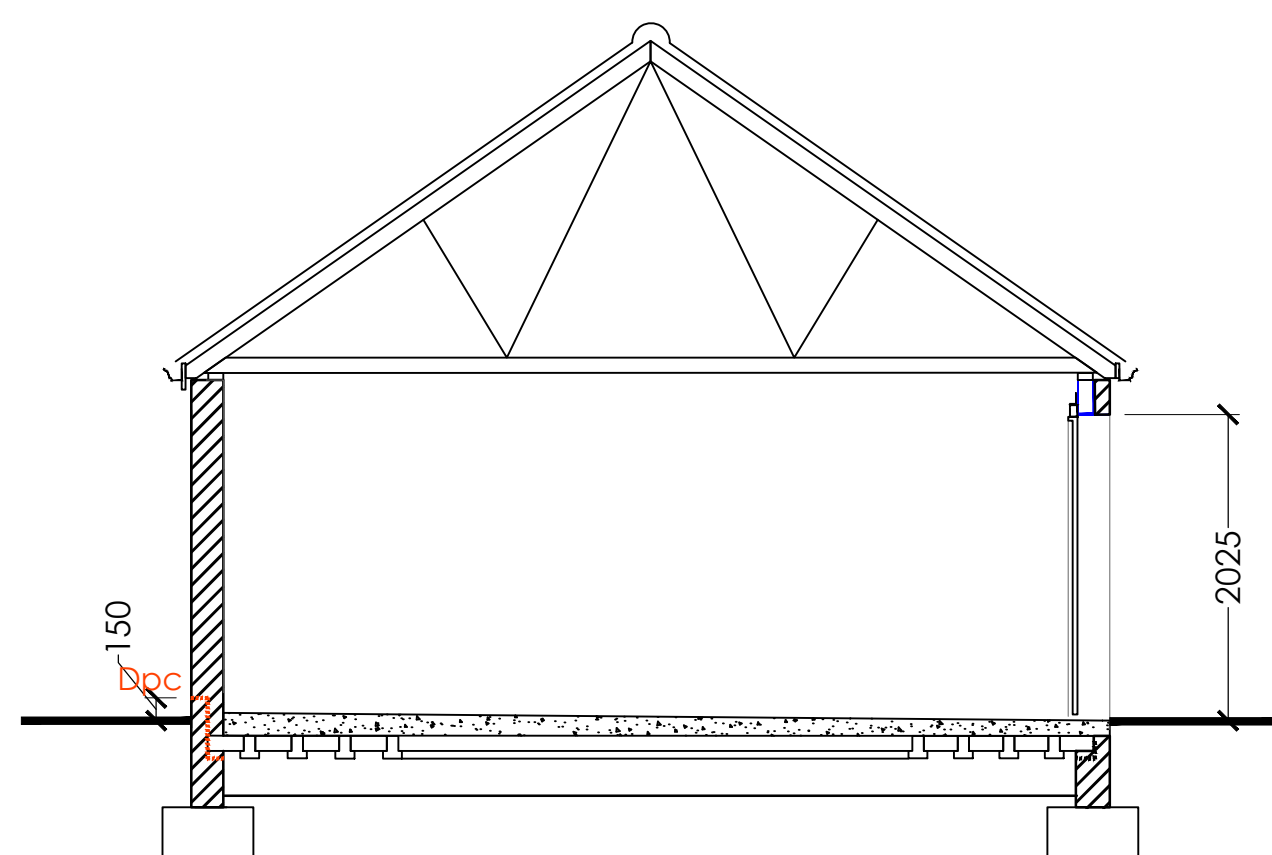

Section G1

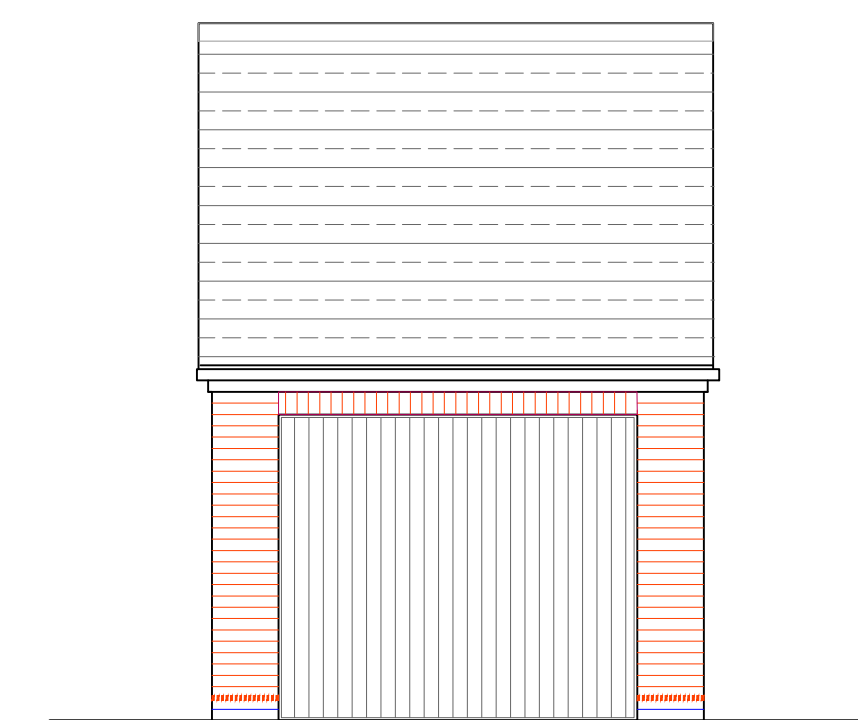

FRONT

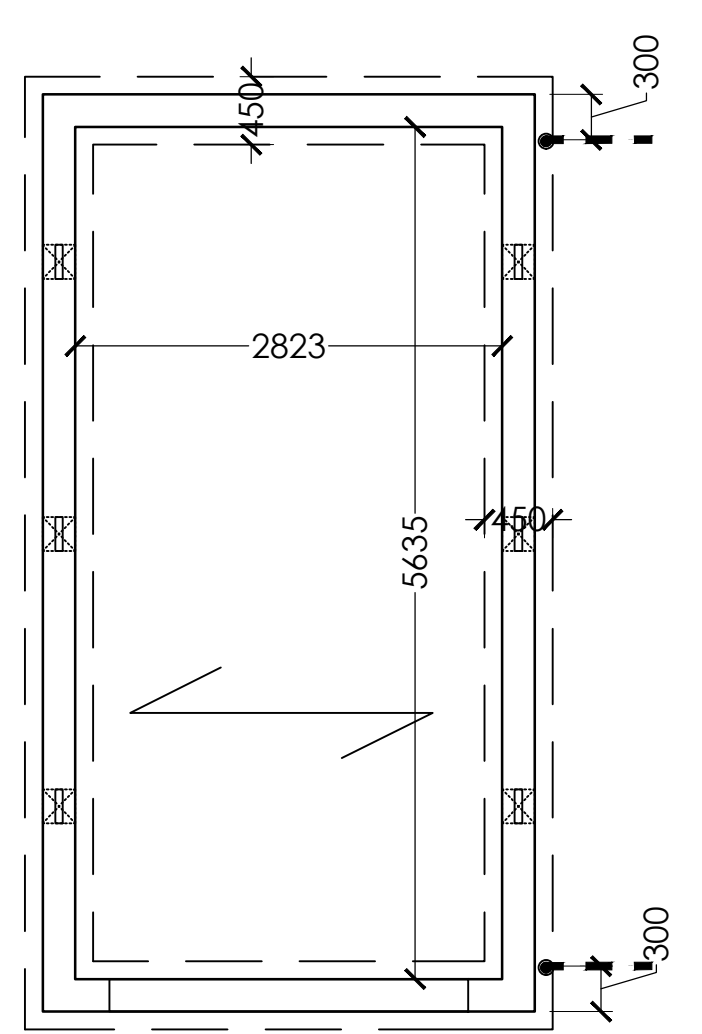

sG SUBS

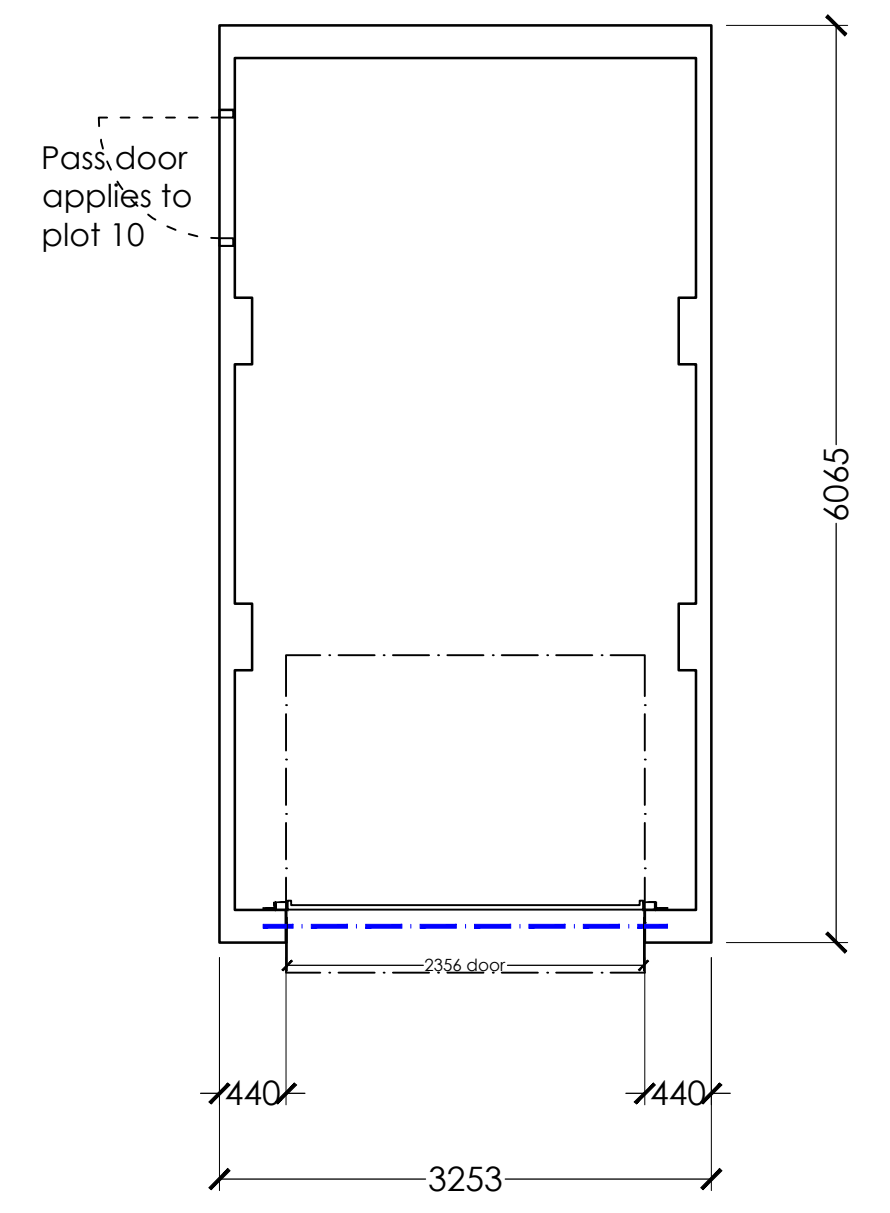

Single Garage PLAN

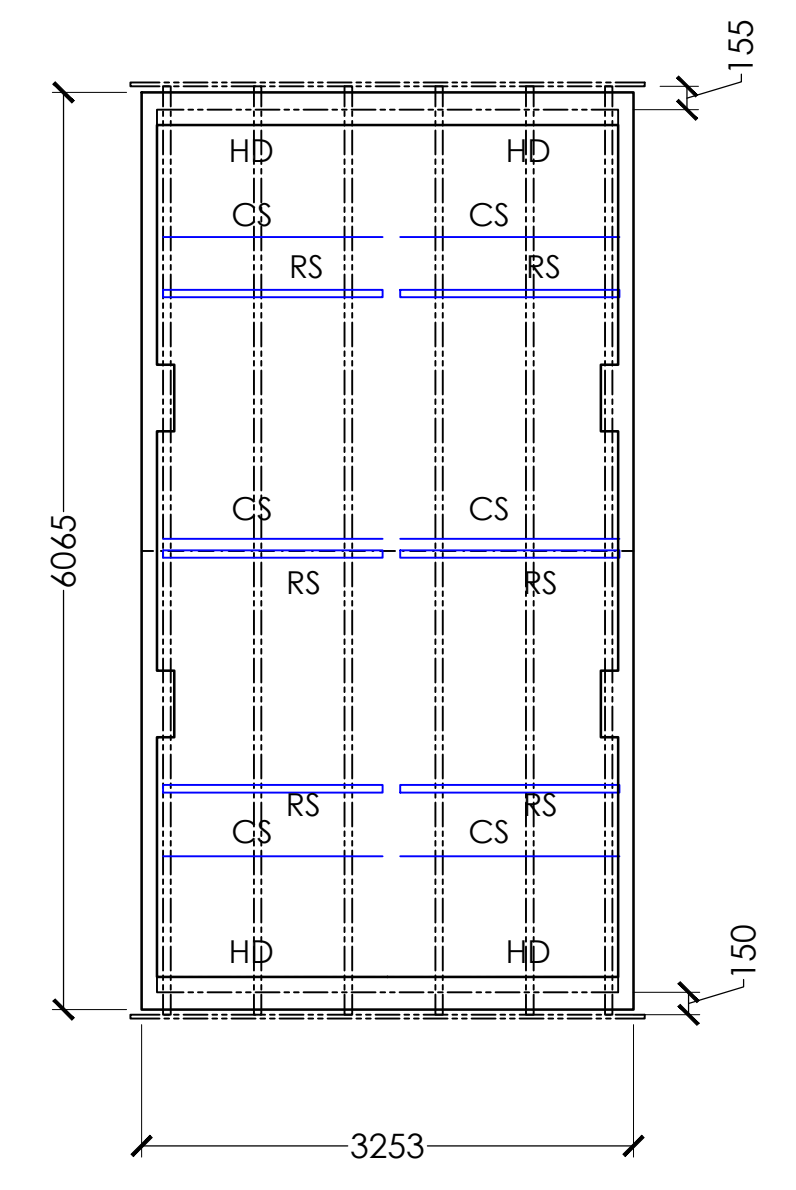

sG ROOF

Rev B: -/mb/ 20.01.20substruc

DRAWING STAGE

F=Feasibility
P=Planning stages
W=Working drawings
AB=As built

W

CLIENT:
WESTPOINT
Fishing line Rd
REDDITCH

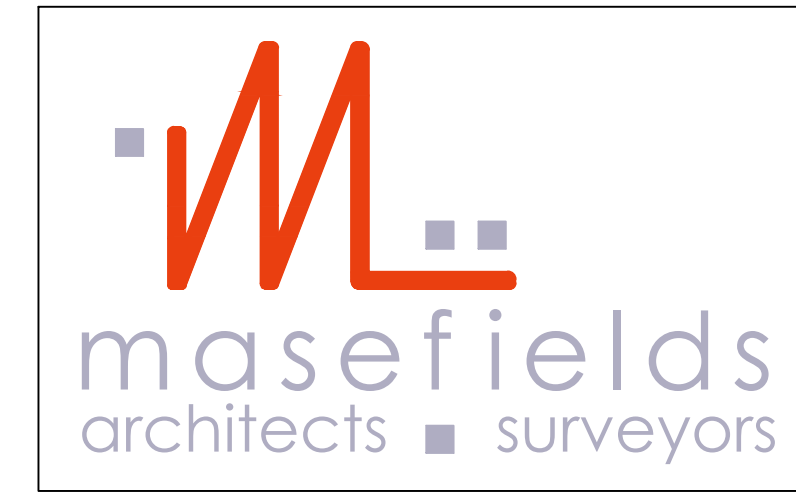

PROJECT:
TAN HOUSE FARM
Studley Rd
REDDITCH

TITLE:
PLANS ELEVATIONS
S.GARAGES

Chartered Architects & Surveyors
Doric House, Church St.
Studley Warwickshire B80 7LG
Tel: 01527 910190 Fax: 01527 857465
Email: architecture@masefields.co.uk

Drawn mb	Ratio 1:100@A3	Checked mb	
Date Mar 17	Job No 3210	Drg No 052	Rev B