BEC BUILDING CONTRACTORS

CONSTRUCTION MANAGEMENT STRATEGY

BEC CONSTRUCTION LIMITED

PROJECT:

**8 NR HOUSES, STAPLE STREET
HERNHILL**

PREPARED BY:

JAKE BARLOW

ISSUE DATE:

03/02/2021

AMENDED:

BEC BUILDING CONTRACTORS

SITE WIDE ELEMENTS

1.100 Positioning of site access and egress points

ACCESS WILL BE VIA DURST ROAD, ONTO OUR TEMPORARY ROAD AND CONTROLLED BY USE OF SIGNAGE, BANKSMAN, AND TIMED DELIVERIES

1.101 Refer to Site drawing for details of access and exit points.

1.102 Traffic Management

In cases of abnormal load deliveries, traffic arrangements shall be established following consultation with the Police, Highways Authority and the Fire Brigade with details shown on the above referenced document.

Arrangements will be made to provide for the safe movement of vehicles and pedestrians in so far as site conditions permit. These arrangements will be regularly reviewed in the light of changing circumstances.

A site drawing appended to this document will show all current routes and be displayed in a prominent position.

Pedestrian routes will be separated from vehicular routes by suitable barriers and clearly signed.

<i>Revision Req. to Plan</i>	<i>See SITE SET UP PLAN</i>
No	Below

1.105 Site Arrangement

A Site set up plan has been prepared describing access/egress, pedestrian and vehicular controls, signage, loading/unloading and vehicle movements, site security arrangements, hoardings and lighting and the location of site accommodation and welfare facilities.

1.106 Site Signage

BEC will identify by clear signage any safety hazards such as weak roofs, dangerous ground and scaffolding, which is out of use. Reliance will not depend entirely on written warning signs where there is a possibility that some people, e.g. young children, may not be able to read them and other measures may need to be implemented.

1.200 Location of Temporary Site Accommodation

1.201 Refer to drawing appended to this document for location of Contractors compound.

The site establishment will be a series of modern Anti Vandal portacabin units. Office space for site staff, conference facilities, and canteen facilities will be sited within a defined area. A segregated area for Site Contractors, their Sub-Contractors and material storage will be as indicated in 6.101 above.

1.300 Welfare Facilities on Site

BEC will provide and maintain a 3m x 2.5 m Metal Anti VANDALOFFICE.

A Site WC will be provided by BEC, in the form of a Mains 2&1 WC for both Female and Males, connected to the existing FW services, which will be maintained with Toilet Paper hand wash and barrier creams.

1.400 Traffic/Pedestrian Routes

BEC BUILDING CONTRACTORS

This has been identified on the proposed Site Set Up Plan, and will be agreed with the Client and formalised and issued to all parties once agreed. The route to site will be Via A299, onto Staple Street into the site.

1.401 Site Traffic & Moving Vehicles

Site traffic will be supervised onto the Site. All Lorries will be routed to the rear access, in off peak times to minimize impact on local residents. We will include wheel washing facilities on site to prevent deposits of mud on the road, and all deliveries and removals to and from site will be netted where needed to stop any debris from public highways. All vehicles will be appropriate size to accommodate the route.

1.402 Protection of the Works

BEC shall set out safe routes for all third parties where they may come into contact with the construction work, using barriers where there is high risk of injury or flicker tape or similar where the risk of injury/interference with the works is low. BEC shall make provision for mesh/secure fencing round the building site of such height as will secure the site operations. Any trenches dug out with the site boundaries shall be similarly protected. The extent of the fencing shall be as shown in the drawing appended to this document.

1.403 Vehicles to be Safely Loaded etc.

BEC shall take such steps as may be necessary to ensure that vehicles leaving the site do not deposit mud or other materials on the public roads system.

1.500 Health Hazards

1.501 Leptospirosis (Weil's Disease) and other Health Hazards

The company procedures relating to health hazards are set out in the Health and Safety Policy Part 2:- Arrangements Section 3.7.2. All operatives exposed to the risk will be issued with a pocket card at induction, which they are expected to retain and present to a medical practitioner if they develop any of the symptoms identified.

1.502 Noise and Vibration Control

We will follow all mitigation measures as defined and detailed in BS 5528: Parts 1 and 2, as well as the CIRIA Environmental good practice on site.

The measure for noise and vibration include, but are not limited to:

Appropriate choice of plant and equipment.

Regular plant maintenance to keep plant in good working condition and reduce noise from machinery.

Careful phasing of operations.

Provision of temporary barriers.

We will carry out tool box talks to ensure operatives are briefed on the requirement to minimise noise, and this will be included in our inductions.

Sufficient monitoring and PPE.

1.503 Air-Borne Pollutants Control Measures for Local Residents

BEC will take sufficient steps to protect the local residents from any airborne pollutants, following guidance from the HSE and BRE part one.

The measure for control of airborne pollutants include, but are not limited to:

All materials with a risk of becoming airborne will be either stored inside, or covered sufficiently to stop spread.

Transportation of materials around site will be carried out with due care and attention and where possible this will be covered, or transported in sealed packaging.

BEC BUILDING CONTRACTORS

Any chemical compounds will be stored in a locked store whilst not in use.
Works where possible will be carried out at the maximum distance from any local residents.

1.504 Control Measures Dust and Air-Borne Pollutants for Operatives

Risk: damage to health.

BEC will take steps generally to control the emission of dust and air borne pollutants following guidance from the HSE and BRE part one :

The measure for dust-suppressing and control include, but are not limited to:

Ordering the correct sized materials to avoid/minimise cutting.

Using a less powerful tool to reduce the dust created.

Change the method of working to avoid dust creation.

Damping the cutting surface with water.

Using on-tool extraction where available.

Provide the correct RPE.

Where possible enclose the work, or limit cutting to a predetermined cutting area with sufficient cover.

1.505 Burning on Site

No site burning is permitted, this includes bonfires.

1.506 Site Operating Times:

All works and ancillary operations which are audible at the site boundary, or at such other place as may be agreed with the Local Planning Authority, shall be carried out only between the following hours:

08 00 Hours and 18 00 Hours on Mondays to Fridays and 08 00 and 13 00 Hours on Saturdays and; at no time on Sundays and Bank Holidays;

The above restrictions also include:

Deliveries to and removal of plant, equipment, machinery and waste from the site must only take place within the permitted hours detailed above;

1.507 Site Lighting

Site lighting will be restricted to internal working, and all lights, when in use will be directed inwards, and located away from windows. This will allow us to minimise any impact on the local residents. No site lighting will be used for security.

1.600 Fire Prevention

BEC shall take note of the advice given in **Fire Prevention on Construction Sites** - the Joint Code of Practice published by the Building Employers' Confederation, the Loss Prevention Council and the National Contractors Group. A Site Fire Safety Plan will be prepared in accordance with the Health and Safety Policy section 3.

1.700 Location of Unloading, Layout and Storage Areas

1.701 All materials to be delivered and unloaded into the Site Compound

1.800 Site Safety and Security

BEC shall form a safe and secure site using Heras security fencing to form a perimeter around the location of the works, and our compound.

We will have a site managed access gate, with restricted access.

CCTV will be used to monitor the site and will record 24 hours a day for the duration of the works.

Our compound will be further secured with motion activated flood lighting, not pointing directly at any adjoining properties.

BEC BUILDING CONTRACTORS

1.900 Consultation and liaison with Local Authorities

1.901 Liaison with the Council's Pollution Control Team

Our Site Manager Mr. Glenn Parker will contact and liaise with LBC Pollution Control Team prior to commencement of the works.

1.902 Our Site Manager Mr. Glenn Parker will be available to liaise with any authorities and is contactable via either email or mobile: Glenn@BEC-Construction.co.uk – 07753 496874.

2.000 Existing conditions

2.001 We have taken a comprehensive condition survey and commit to restore the roads to the condition before the works were taken. A copy of the photos can be collected or posted if required.

2.100 Public Relations

2.101 Letter Drop

A letter drop will be issued to all local residents, including our complaints procedures, and direct contact information to allow easy consultation and liaison.

2.102 Entrance Signage

Our entrance sign board has contact information for both the site and project manager, who can be reached directly 24 hours a day. This allows us to take a hands on approach to liaising with the public, and they can voice any concerns in person and we can resolve them directly.

2.200 Procedure for emergency deviation of the agreed working hours

2.201 See Construction Phase Health and Safety Plan for all our emergency procedures.

Appendix A – Site Set Up Plan

Registered office: The Granary, Spratling Court, Spratling Street, Ramsgate, Kent, CT12 5AN

Registered No 4969500

Vat No.824 0368 46

Website www.bec-construction.co.uk

Rob Barlow mobile 07775 592512

KCC APPROVED CONTRACTOR

BEC BUILDING CONTRACTORS

We include our site set up plan, with a large angled entrance to allow for arctic vehicles, which we anticipate will be the largest vehicles to visit site.

The site set up will be formed to accommodate these vehicles, including a turning circle and offloading area.

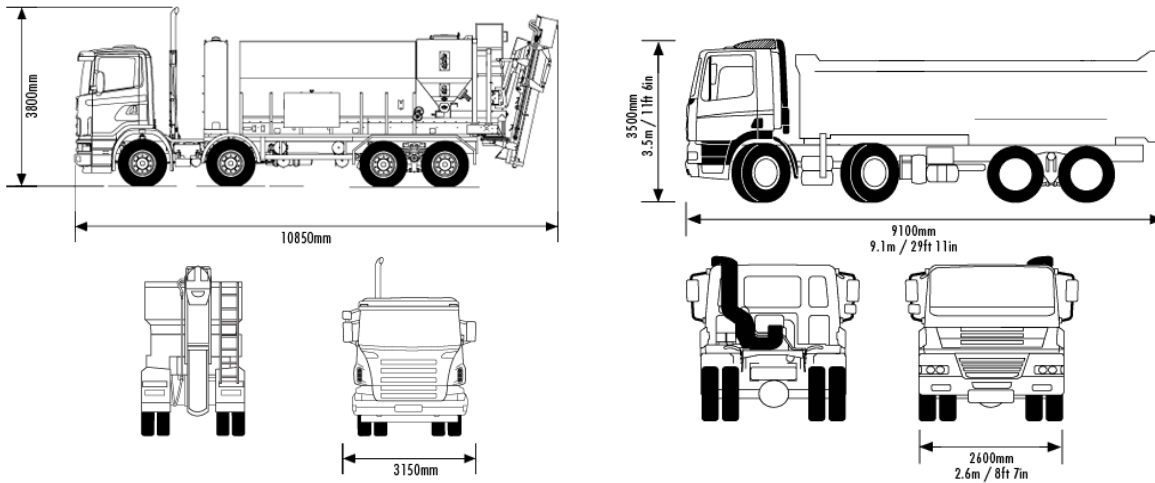

Appendix B

BEC BUILDING CONTRACTORS

Our proposed route for all site traffic will be:

- A299
- Staple Street
- Site Compound

This route will be distributed to all material and sub contractors with delivery responsibilities, as well as the strict instructions to call 30 minutes ahead.

Likely HGV Movements:

	8AM - 12PM	12PM - 1PM	1PM - 4PM
Amount of deliveries	2-4 movements, spaced out to allow 1 hour offloading and 30 minutes to return to the nearest A road (A256)	No Deliveries	2-4 movements, spaced out to allow 1 hour offloading and 30 minutes to return to the nearest A road (A256)

The anticipated movement of HGV will be limited to either a single HGV delivery or two smaller vehicle deliveries per AM/PM, per day.

We would anticipate likely HGV movements be to two to four per AM/PM to allow ample time to offload and distribute materials and to ensure two vehicles do not meet along the route.

8.00AM – 12.00PM	1.00PM – 4.00PM
8.00AM – First movement – HGV arrives at site	1.00PM – Fifth movement – HGV arrives at site
8.00AM – 9.00AM – HGV is offloaded, wheels washed if required	1.00PM – 2.00PM – HGV is offloaded, wheels washed if required
9.00AM – Second movement – Leaves site towards A256 – deemed to have reached by 9.30AM	2.00PM – Sixth movement – Leaves site towards A256 – deemed to have reached by 2.30PM
10.00 AM – Third movement – HGV arrives at site	3.00PM – Seventh movement – HGV arrives at site
10.00AM – 11.00 AM – HGV is offloaded, wheels washed if required	3.00PM – 4.00 PM – HGV is offloaded, wheels washed if required
11.00AM – Forth movement – Leaves site towards A256 – deemed to have reached by 11.30AM	4.00PM – Eighth movement – Leaves site towards A256 – deemed to have reached by 4.30PM

Registered office: The Granary, Spratling Court, Spratling Street, Ramsgate, Kent, CT12 5AN

Registered No 4969500

Vat No.824 0368 46

Website www.bec-construction.co.uk

Rob Barlow mobile 07775 592512

KCC APPROVED CONTRACTOR