

Bin provision per house- 1 black refuse bins (180l)/
 1 recycling bin (240l)/ 1 x garden waste bin (240l)
 Food waste bin (23l)
 Cycles- 2 per house

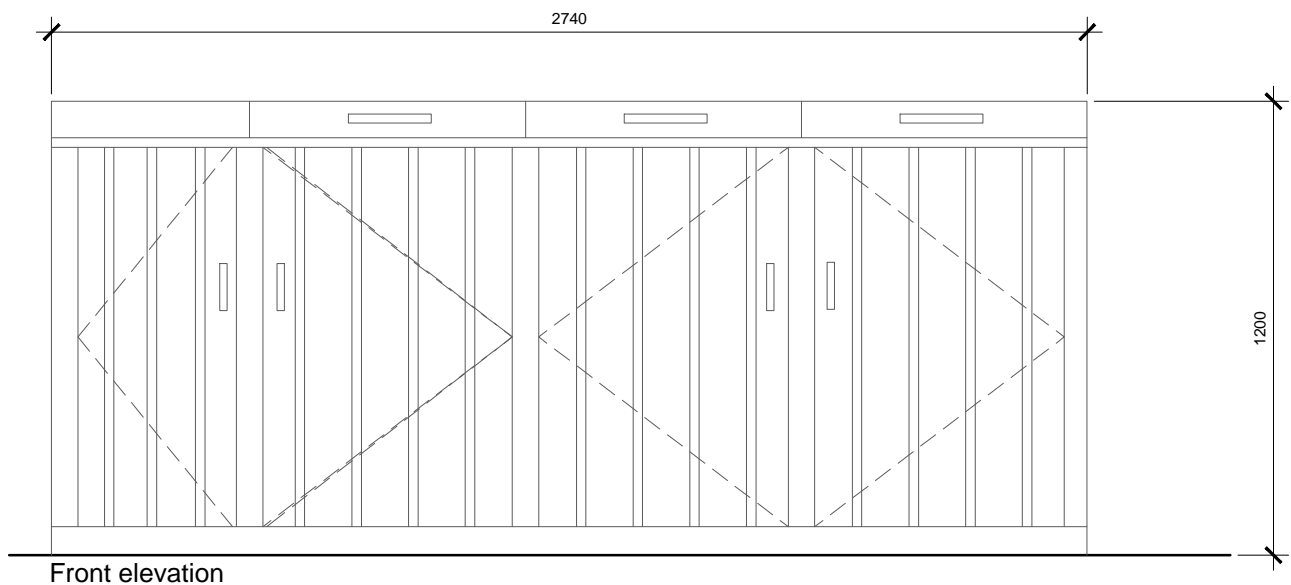

Front elevation

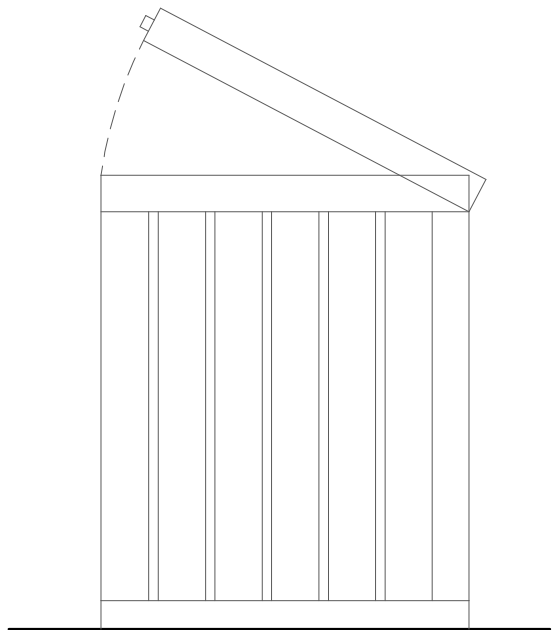

Side elevation showing hinged access lid

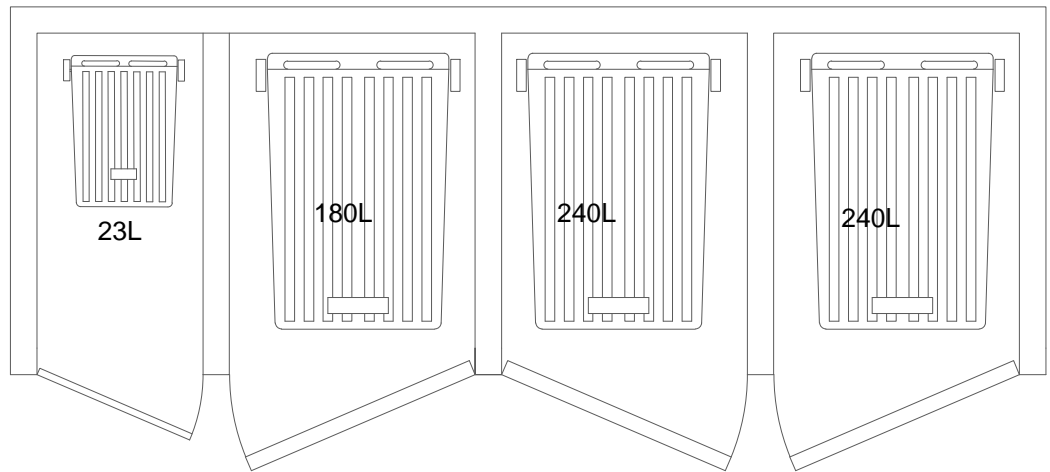

Plan



Typical bin store for 1 house
 Material: vertical hit and miss pressure-treated pine

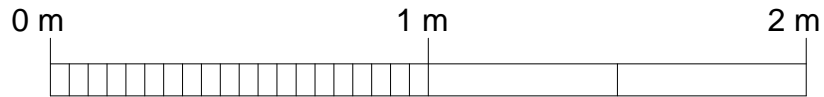

1:20 SCALE

PLANNING

Client
 The Rookery Estates Limited

Project
 Elmscroft Farm
 Charlton Lane
 West Farleigh
 ME16 0NY



The Civic Centre, St Mary's Road, Swanley, Kent, BR8 7BU.
 Phone: 01322 479561 Mobile: 07802 182202
 info@haskinsdesigns.co.uk Website: haskinsdesigns.co.uk

Title
 Typical bin store

Project No.
173

Scale
 1:20@A3

Drawn
 GH

Check
 JH

Drawing No.

Revision

Date